

Self priming electropump made in cast iron suitable domestic pressure boosting, small irrigation, gardening, car washing, tanks and pools emptying and pumping clear water in general.



SPECIFICATIONS

- Maximum working pressure:
6 bar for AGA 0,60-0.75-1.00
10 bar for the other models
- Maximum liquid temperature:
35°C according EN 60335-2-41 for domestic uses
45°C for other uses
- Maximum suction: 8 mts

MATERIALS

- Pump body in cast iron
- Casing cover in AISI 304 for AGA 0.60-0.75-1.00
- Shaft in AISI 416 for AGA 0.60-0.75-1.00,
in AISI 303 for the other models

- Impeller in tecnopolymer for AGA 0.60-0.75-1.00,
in brass for the other models
- Mechanical seal in carbon/ceramic/NBR

TECHNICAL DATA

- Asincronous 2 poles motor
- Insulation class F
- Protection degree IP44
- 1~230V ± 10% 50Hz, 3~230/400V ± 10% 50Hz
- Permanent split capacitor and automatic thermal overload protection for single-phase version
- Thermal protection to be provided by the user for three-phase version
- DNM 1"

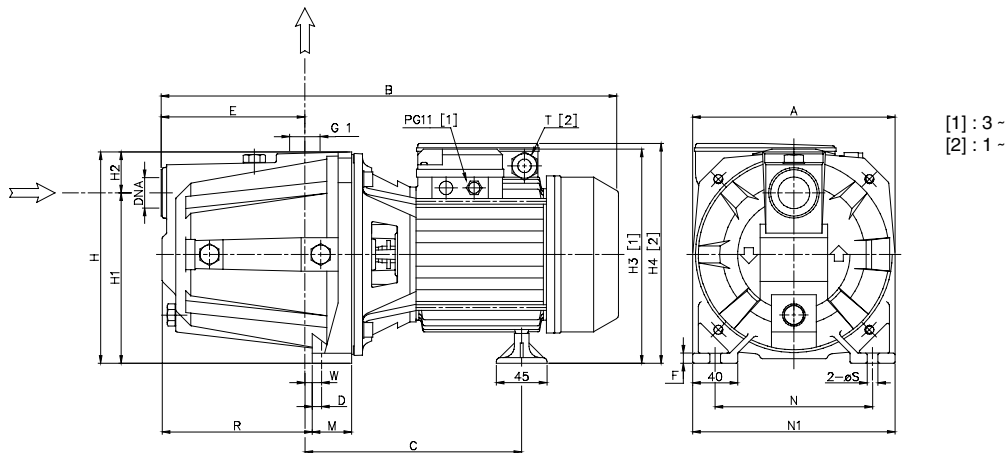

[1] : 3 -
[2] : 1 -

DIMENSIONAL TABLE

Pump type		Dimensions (mm)																	Weight kg			
		A	B		C	D	E	F	H	H1	H2	H3	H4	M	N	N1	R	T		W	S	DNA
Single-phase	Three-phase		1~	3~								3~	1~					1~				
AGA 0.60 M	AGA 0.60 T	180	405	405	195	10,3	127	9	185	152	33	197,5	199	40	140	180	128,5	PG11	11,8	9,5	G 1	12,5
AGA 0.75 M	AGA 0.75 T	180	405	405	195	10,3	127	9	185	152	33	197,5	199	40	140	180	128,5	PG11	11,8	9,5	G 1	13
AGA 1.00 M	AGA 1.00 T	180	405	405	195	10,3	127	9	185	152	33	197,5	199	40	140	180	128,5	PG11	11,8	9,5	G 1	14
AGA 1.50 M	AGA 1.50 T	220	495	495	244	10	157	10	223	170	53	229	247	48	180	220	167,5	PG13,5	15,5	9	G 1½	26
AGA 2.00 M	AGA 2.00 T	220	508	495	244	10	157	10	223	170	53	229	247	48	180	220	167,5	PG13,5	15,5	9	G 1½	27
-	AGA 3.00 T	220	-	508	244	10	157	10	223	170	53	229	-	48	180	220	167,5	-	15,5	9	G 1½	27
AGC 1.50 M	AGC 1.50 T	220	495	495	244	10	157	10	223	170	53	229	247	48	180	220	167,5	PG13,5	15,5	9	G 1½	26
AGC 2.00 M	AGC 2.00 T	220	508	495	244	10	157	10	223	170	53	229	247	48	180	220	167,5	PG13,5	15,5	9	G 1½	27
-	AGC 3.00 T	220	-	508	244	10	157	10	223	170	53	229	-	48	180	220	167,5	-	15,5	9	G 1½	27

PERFORMANCE CURVES (according to ISO 9906 grade 2)

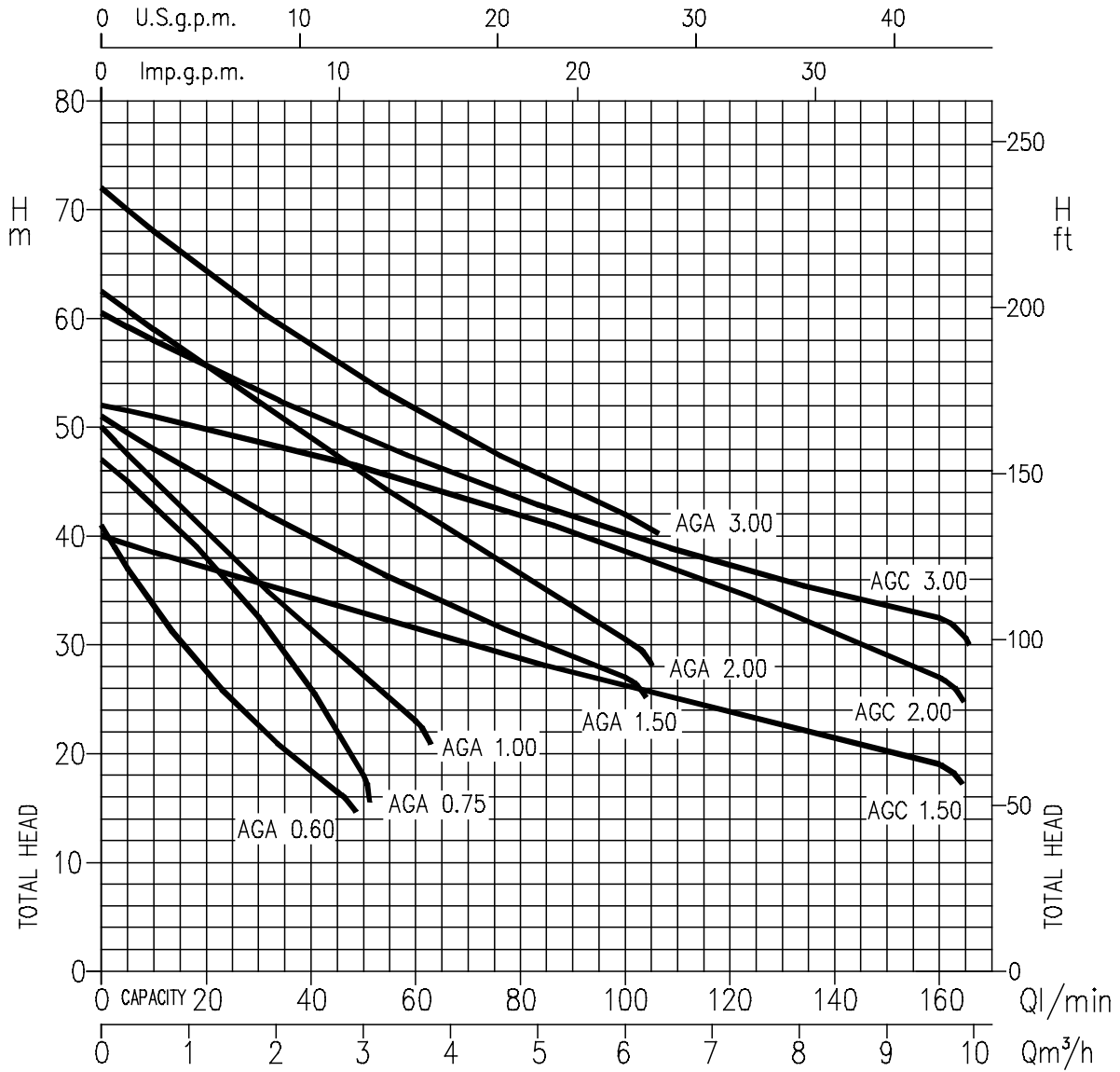

PERFORMANCE TABLE

Pump type Single-phase 230V 50Hz	Pump type Three-phase 230/400V 50Hz	kW	Capacitor		Absorbed Current (A)			l/min m³/h	Q=Capacity													
			µF	Vc	Single-phase	Three-phase 230V 400V			5	10	20	30	45	50	60	80	100	130	160			
									H=Total head													
AGA 0.60 M	AGA 0.60 T	0,44	12,5	450	3,1	2,1	1,2	37	33,4	27,1	22	16,5	-	-	-	-	-	-	-	-	-	-
AGA 0.75 M	AGA 0.75 T	0,55	14	450	4,0	2,8	1,6	45	42,8	37,9	32	21,9	18	-	-	-	-	-	-	-	-	-
AGA 1.00 M	AGA 1.00 T	0,75	20	450	5,5	3,6	2,1	47,5	45	40,3	35,7	29,1	27	23	-	-	-	-	-	-	-	-
AGA 1.50 M	AGA 1.50 T	1,1	35	450	8,1	5,3	3,0	-	48	45,1	42,4	38,6	37,4	35,1	30,8	27	-	-	-	-	-	-
AGA 2.00 M	AGA 2.00 T	1,5	40	450	9,8	6,3	3,6	-	59	55,6	52,2	47,3	45,7	42,5	36,4	30,5	-	-	-	-	-	-
-	AGA 3.00 T	2,2	-	-	-	7,9	4,7	-	68	64,3	60,8	55,9	54,4	51,6	46,4	42	-	-	-	-	-	-
AGC 1.50 M	AGC 1.50 T	1,1	35	450	8,6	5,8	3,3	-	38,5	37	35,6	33,5	32,7	31,4	28,7	26,1	22,4	19	-	-	-	-
AGC 2.00 M	AGC 2.00 T	1,5	40	450	10,5	6,8	3,9	-	51	49,9	48,8	46,9	46,3	44,9	42	38,7	33,2	27	-	-	-	-
-	AGC 3.00 T	2,2	-	-	-	7,9	4,6	-	58	55,6	53,5	50,1	49,1	47,1	43,4	40,2	35,9	32,5	-	-	-	-